

The DSK safe range of drug safes is the most popular and economical drug safe to comply with current Australian State Health Department Regulations regarding the storage of schedule 8 drugs



Ideal for Pharmacies, Hospitals, Aged Care, Nursing Homes, Vets



The DSK Drug Safe is fitted with a six lever pick resistant lock to ensure compliance to the strict rules for storing drugs. The safes can also be ordered with an electronic digital lock for ease of use and audit trail to track user access and times.

Featuring pre drilled anchor holes in the rear and base, adjustable shelves and high quality durable paint the DSK range is designed for years of hard wear and tear.

Optional Locking:

- Securam Digital Lock
- Securam Digital Lock with Audit Trail
- Access Control Lock

Specifications

- 6 Lever Pick-Resistant Lock available as standard
- Anti-tamper re-locking device on lock
- Hardened anti-drill plates surrounding the lock
- Solid steel 10mm body
- Solid steel 10mm door
- Solid steel 20mm bolt-work
- External hinges with internal anti-pry dead bar.
- Australian Health Department compliant
- Durable hardened paint finish
- Adjustable Shelving
- Pre-drilled 12mm anchoring holes



**Unsure of your State Regulations and Requirements?
Call us today 1800 080 280 for more details.**

Model	External (mm)			Internal (mm)			Weight (kg)	Shelves (adj)
	Height	Width	Depth	Height	Width	Depth		
DSK1	457	305	180	437	285	115	45	3
DSK1/300	457	305	300	437	285	235	63	3
DSK2	610	457	180	590	437	115	73	4
DSK2/300	610	457	300	590	437	235	99	4
DSK3	1220	762	400	1200	742	305	325	5
DSK4	1525	762	400	1505	742	305	390	5
DSK5	920	460	300	900	440	235	139	4
DSK6	800	500	300	780	480	235	132	4

DEPTH MEASUREMENT DOES NOT INCLUDE THE HANDLE, KEYPAD OR HINGES. PLEASE ALLOW 50MM. Due to Multifile constantly striving to deliver better products; sizes and colours may vary slightly.

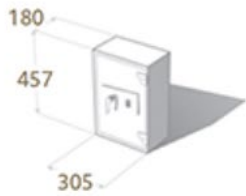

● DSK1

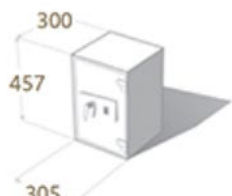

● DSK1/300

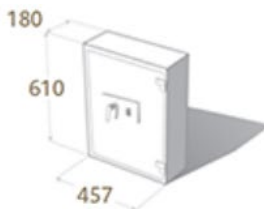

● DSK2

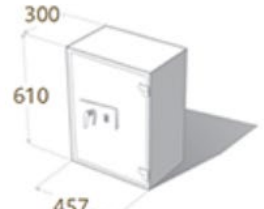

● DSK2/300

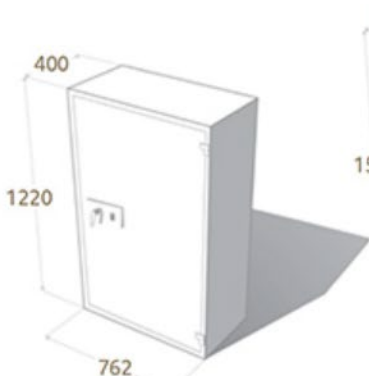

● DSK3

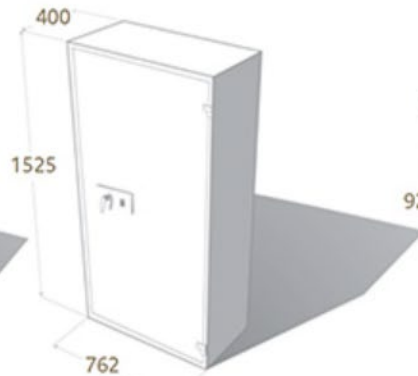

● DSK4

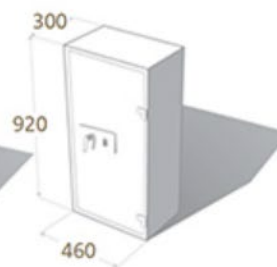

● DSK5

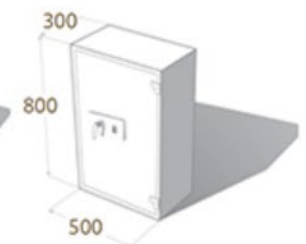

● DSK6